



Faculty/Graduate School of
AGRICULTURE
KYOTO UNIVERSITY

Guide to the Faculty of Agriculture, Kyoto University Exchange Programs 2020-2021

Undergraduate Level

Faculty of Agriculture
KYOTO UNIVERSITY

CONTENTS

Outline	P. 2
Flowchart of Application Procedures	P. 6

Note:

The Faculty of Agriculture, Kyoto University accepts exchange students from our partner institutions based on the student exchange agreement.

If the contents of the agreement differ from this guide, the agreement shall always take precedence over this guide.

Outline

We accept exchange students from our partner institutions based on the student exchange agreement as “Special Auditor” which is a non-degree seeking status at Kyoto University’s Faculty of Agriculture.

Academic Calendar (2020-2021)

Fall Semester: October 1, 2020 to March 31, 2021

Spring Semester: April 1, 2021 to September 30, 2021

Note: Academic year of Kyoto University begins in April and ends in March.

Eligibility

Each applicant must:

- (1) Be currently enrolled at a non-Japanese academic institution with which Kyoto University has a student exchange agreement.
- (2) Agree to leave Kyoto University and return to the home institution upon completion of the exchange program.
- (3) Have excellent academic and personal records.
- (4) Have a concrete purpose for studying in Japan.

Tuition and Fees

Based on the student exchange agreement, exchange students will be exempted from examination fees, matriculation fees, and tuition at Kyoto University.

Course Registration

Exchange students may earn a maximum of forty credits per year.

A minimum number of courses to take is set per semester: Seven courses (including a maximum of two Japanese Language courses).

Each course usually comprises 90 minutes of lecture time per week (a course usually carries two credits). Those who would like to take other than the classroom lecture (e.g.

seminar, experimental work) are required to get permission in advance.

For details:

<http://www.kais.kyoto-u.ac.jp/japanese/undergraduate/>

<http://www.z.k.kyoto-u.ac.jp/introduction/la-english>

Notes:

Almost all the courses at Kyoto University are offered in Japanese. However, more than 200 English-taught courses by the Institute for Liberal Arts and Sciences (hereafter 'ILAS') are available.

The syllabus for AY 2020-2021 will be updated in late March.

➤ **Japanese Language Study**

The Education Center for Japanese Language and Culture of 'ILAS' offers Japanese language classes in the Liberal Arts and Sciences curriculum. These are divided into five levels: Elementary I, Elementary II, Intermediate I, Intermediate II and Advanced. Exchange students may take a maximum of six courses per semester.

For details:

[http://www.z.k.kyoto-u.ac.jp/introduction/education-center-for-japanese/
japanese-language-classes/zenkyo-japanese/for-kokanryuugakusei](http://www.z.k.kyoto-u.ac.jp/introduction/education-center-for-japanese/japanese-language-classes/zenkyo-japanese/for-kokanryuugakusei)

[http://www.z.k.kyoto-u.ac.jp/introduction/education-center-for-japanese/
japanese-language-classes/zenkyo-japanese/notes](http://www.z.k.kyoto-u.ac.jp/introduction/education-center-for-japanese/japanese-language-classes/zenkyo-japanese/notes)

Language Requirements

Those who take Japanese-taught courses should have sufficient Japanese language proficiency (N1 level Japanese Language Proficiency Test or an equivalent level is desirable).

Those who take English-taught courses should be proficient in English (TOEFL iBT 79 (or equivalent IELTS score) or higher is desirable). Though Japanese language proficiency is not required, it is preferable to acquire a basic knowledge of Japanese in order to make life in Japan smoother and easier.

Entering Japan

Those who wish to study at Japanese universities are required to go through certain procedures. Exchange students at Kyoto University, for example, must possess a valid passport and "Student" visa. In order to apply for "Student" visa, an official certificate "Certificate of Eligibility" issued by the Immigration Bureau is required.

For details:

(Student Visa) https://www.mofa.go.jp/j_info/visit/visa/long/visa6.html

(Certificate of Eligibility) <https://kuiso.oc.kyoto-u.ac.jp/visa/proxy/en>

Japanese nationals may enroll in the Exchange Program without these procedures.

Mandatory Insurance

➤ **Health insurance**

Japanese law stipulates that all university students based in Japan must enroll in the country's National Health Insurance (NHI) program, which costs around 2,000 yen per month. However, the NHI program does not provide full coverage against death, accidents, loss, fire, or full damages compensation. It is therefore necessary to enroll in additional insurance programs.

➤ **Gakkensai**

Personal Accident Insurance for Students Pursuing Education and Research (including additional coverage for commuting accidents)

(Premium) 1,000 yen for one year coverage

Note: Each student is responsible for the service fee.

➤ **Gakubai**

University Co-op's Personal Liability Insurance for Students

(Premium) approximately 2,000 yen for one year

(Membership fee) 4,000 yen

Only student members of Univ. Co-op can enroll in Gakubai. Therefore, it is required to pay the membership fee and become a member of Univ. Co-op at the same time.

Note: The membership fee is refundable by taking necessary procedures before leaving Kyoto University.

In addition, international students are advised to purchase travel insurance in their countries in order to ensure adequate coverage. In case of any emergency, we recommend students to bring along sufficient funds. (There was a case that a student had an operation and needed to settle a huge amount of medical fees temporarily.)

Documents to Submit

1. Application Form (Form 1)
2. Statement of Purpose (Form2)
3. Official Request for Acceptance (Form3-1)
4. Recommendation Letter (Form3-2)
5. Health Certificate (Form4)
6. One Certificate of Enrollment
7. One Original Academic Transcript
8. One Passport Copy (the page with your photo, name, and passport number)
9. One Copy of the Official Score of Japanese or English Proficiency Test*
*Japanese Language Proficiency Test, TOEFL-iBT or IELTS (English) are acceptable.
10. Two photos (see “Photo Requirement”)

Note:

Application should be submitted to Kyoto University through the international office of applicant’s home institution. Applications submitted directly by students are NOT accepted.

Flowchart of Application Procedures

Special Auditor

Read this guide.



Complete application forms with the related documents.



Submit all the required application documents to the International Office of home institution.



Application Deadline

-For enrollment in October, 2020: the end of February, 2020

-For enrollment in April, 2021: the end of September, 2020



Notification of Admission will be sent to the partner institution's office

-For enrollment in October, 2020: in July, 2020

-For enrollment in April, 2021: in January, 2021



Pre-Arrival Preparation

Information about Visa and Accommodation will be e-mailed to students directly around July/January.

<CONTACT ADDRESS>

Student Affairs Office,

Faculty of Agriculture,

Kyoto University

Kitashirakawa Oiwake-cho, Sakyo-ku,

Kyoto 606-8502, JAPAN

E-mail: agri-kyoumu1@mail2.adm.kyoto-u.ac.jp

Fax: +81-75-753-6005

Photo Requirement

You need to submit 2 photos as specified below. Please write your full name on the back of photo.

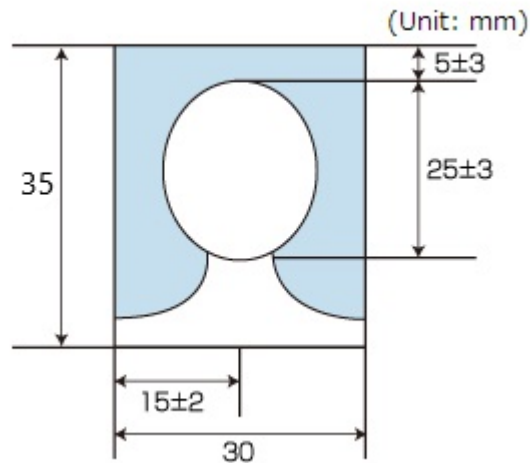

1. A photo that shows the applicant him/herself alone.
2. A photo of the dimensions specified in the drawing above, excluding the photo's outer border (the dimension of the face refers to the portion from the top of the head [including the hair] to the lower end of the chin).
3. The person should face squarely to the front and remove hats, caps or head coverings.
4. No background or shadows.
5. Must be clear.
6. Must be taken within one month prior to submission.
7. Must be different from the one on your passport.